

ELECTRA

Adaptive Shape-Based Autorouter

- Adaptive Shape-Based Autorouting technology
- Multi-pass conflict reduction algorithm
- SPECCTRA® format support
- Advanced Rules constraints
- Reasonable Cost of ownership!
- Available on Windows, Linux and Solaris platforms

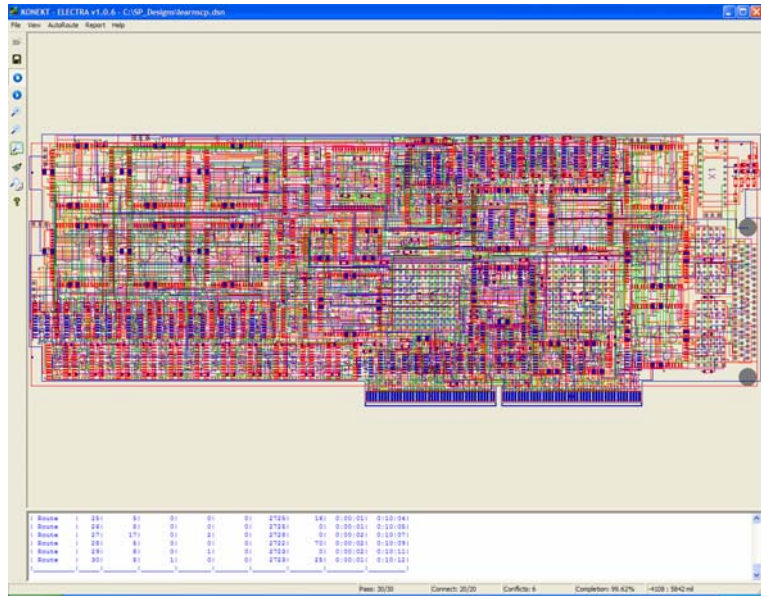

Shape-based Technology

ELECTRA™ is a new generation of Shape-Based Autorouting software for PC boards. By contrast with traditional gridded maze autorouters, a shape-based approach allows for more efficient use of routing area and is more suited to handle complex design rules requirements of high density SMD or through holes boards.

Adaptive Autorouting

ELECTRA uses a multi-pass cost-based conflict reduction algorithm to find a routing solution adapting to the natural flow of the nets. Adaptive routing

algorithm is the only proven approach to reach high completion rate. ELECTRA provides immediate feedback on the routing progress and conflict reduction rate.

CAD System Plug-in

ELECTRA supports industry standard format by reading design file (DSN). Routing results are saved into standard route file format (RTE) or session file (SES). ELECTRA is designed to plug into an existing PCB CAD system environment that is supporting SPECCTRA design file format.

FEATURES

- Gridless routing of up to 256 layers
- Wire and Clearance rule by layer, net class & net
- Via rule by net class & net
- Vias under SMD pads
- SMD escape fanout control
- Routes SMDs on both sides
- Memory routing pass
- Blind/buried/staggered vias
- Split Plane/Ground Planes support
- Customizable cost factors
- Post-route cleanup optimization
- Reads rules embedded in SPECCTRA DSN
- Batch routing option
- Scriptable routing strategy (DO file)

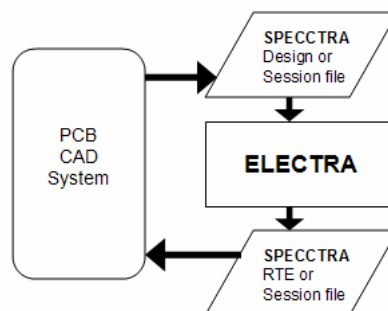

Advanced Rules

Support

ELECTRA is driven by layout rules. Each net can have its own minimum clearance and wiring constraints. Net class and nets can be constrained to be routed on specific layers and use different rules for each of the layers. Different via type can be assigned to net classes,

these could be used for example for power and ground current carrying requirements. The autorouter finds a solution that simultaneously respects all defined rules.

Product Configurations

ELECTRA is available and upgradable in four different configurations with unlimited number of pins:

- ELECTRA **2L** – for single and double sided boards
- ELECTRA **4L** – for designs having a maximum of four signal layers
- ELECTRA **6L** – for designs having a maximum of six signal layers
- ELECTRA **UL** - for designs having a maximum of 256 layers

ELECTRA v1.03
Benchmarks of 8 sample designs autorouted at 100%
Routing performed on Intel P4 - 1.2Ghz running XP

	Demo6	Demo5	Demo4	Demo3	Inter	Demo7	Demo2	Demo1
Via count ELECTRA	309 (+1%)	120 (-45%)	126 (-30%)	71 (-39%)	87 (-24%)	703 (+5%)	235 (-7%)	6 (+14%)
Routed Length ELECTRA	421778 (+5%)	670514 (-13%)	135011 (-5%)	673420 (-3%)	11452 (-1.3%)	648675 (-10%)	459177 (+3%)	83123 (+1.4%)
Run Time (mm:ss) ELECTRA	00:34 (5.3x)	00:25 (12.6x)	00:11 (6x)	00:39 (3x)	00:12 (6.6x)	04:45 (3.3x)	00:26 (3.6x)	00:07 (2x)
Via count B-Router	304 (-1%)	218 (+45%)	180 (+30%)	117 (+39%)	115 (+24%)	668 (-5%)	252 (+7%)	5 (-14%)
Routed Length B-Router	400175 (-5%)	769065 (+13%)	142679 (+5%)	693840 (+3%)	11606 (+1.3%)	714441 (+10%)	444827 (-3%)	81962 (-1.4%)
Run Time (mm:ss) B-Router	03:04 (-5.3x)	05:15 (-12.6x)	01:05 (-6x)	01:55 (-3x)	01:20 (-6.6x)	15:50 (-3.3x)	01:35 (-3.6x)	00:15 (-2x)